

NanoTron

Dual Relay Control

Microprocessor Control of:

- **Conductivity**
- **Feed Timer**
 - Pulse
 - 28-Day
 - Recycle
 - Post Bleed
 - Reminder
 - Batch

Key Features

- Compact Design
- Simple Step Through Menu
- NEMA 4X Style Enclosure
- Raised Dome Keypad
- Non-Volatile Memory
- Water Meter Totalizer
- 2 Year Warranty
- Available Flow Switch
- Prewired Configuration

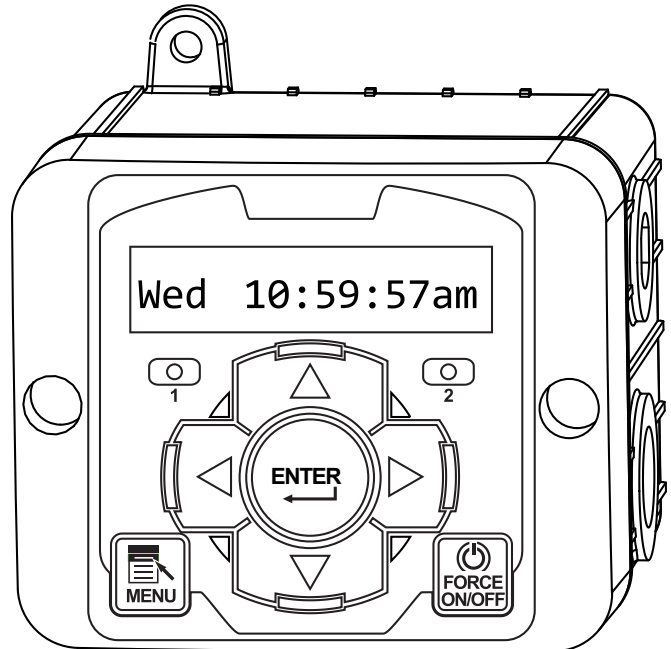

Application

The NanoTron is a compact, dual relay microprocessor-based controller with many standard features. NanoTron models are available to control conductivity and one selectable feed timer, or two independently programmable feed timers.

The NanoTron platform provides an economical option for conductivity control of a cooling tower, boiler, or other recirculating water system. Selectable feed timer options include: pulse, post bleed, with bleed, recycle, 28-day, batch and reminder.

Build a Model

The model number starts with NANO followed by a single control function then any additional options.
Example: NANO-C-E

Control Functions

- C** = Tower conductivity with 1 feed timer
- C4** = Tank mount conductivity with 1 feed timer
- B2** = Boiler conductivity with 1 feed timer
- F2** = Two feed timers

Options

- A** = 120 VAC conduit connections
- A3** = Liquid tight only with CE mark, 120 VAC
- A5** = USA power cord and no relay cord
- A7** = Australian power cord (240 VAC)
- E** = Float style flow switch assembly; 140 PSI @ 75°F
- E3** = Paddle flow switch with PVC flow assembly
- E5** = Paddle flow switch with brass assembly; 250 PSI @ 75°F (order appropriate probes)
- E6** = Flow switch connection only with cable
- O1** = 4-20mA output (only for Nano C/B models)
- W** = Larger enclosure with clear lockable cover
- Y** = ETL agency listing

All NanoTron units include:

- 2 relay outputs with “force on” mode
- 1 low drum alarm input
- 1 water meter input with accumulator and totalizer

NANO-F2 units include two drum level and water meter inputs and timer selections include: pulse, recycle, batch and 28-day.

Conductivity units can be set for rising or falling and continuous, timed or sample and hold.

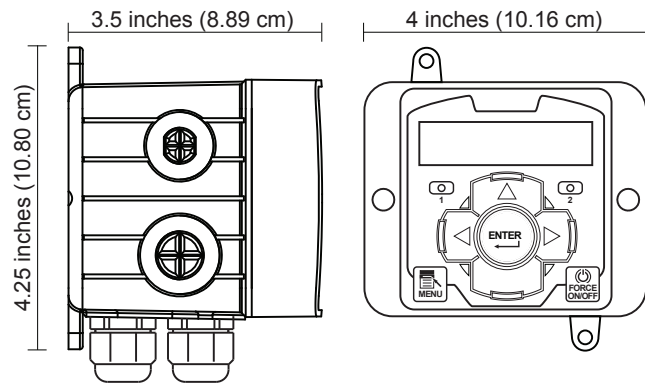

Specifications

Electrical

- **Input:** 100-240 VAC, 50/60 Hz
- **Control:** Input VAC, 3 Amp / relay
Prewired units are supplied with an 8' (248.84 cm) power cord and 8" (20.32 cm) output receptacles.
- **Water Meter:** Dry contact
Hall-effect; +5 VDC input

Operational

- **Conductivity Scale Ranges:**
 - Low:** 5-1,000µS
 - Mid:** 100-5,000µS
 - High:** 1,000-20,000µS for towers
1,000-10,000µS for boilers
- **Display:** LCD 1 x 16 backlit alphanumeric
- **Timers included in all models:**
 - Pulse:** 1-9999 counts, MM:SS run time
 - Recycle:** HH:MM off cycle, MM:SS on cycle
 - 28-Day:** Weeks, Days, HH:MM run time
- **Conductivity models also include:**
 - Batch:** Manual 1 time (on MM:SS)
 - Reminder:** 1-99 days
 - With Bleed:** HH:MM limit time
 - Post Bleed:** 0-100%, HH:MM limit time
 - Utility:** Relay always ON & flow dependent

Enclosure

NEMA 4X style high impact thermoplastic

Environment

Ambient temperature: 0° to 125°F (-17 to 52°C)
Relative humidity: 0 to 100%

Electrode

Standard tower electrode is supplied in a 3/4" (1.91 cm) Sch. 80 PVC female slip tee with quick release nut.

- **TE-4A** 120 PSI (8.2 bar) @ 125°F (51.67°C)
 - **DC-4A** 180°F (82.22°C) max tank mount electrode
- Boiler electrodes supplied with 1" (2.54 cm) MNPT bushing
- **BE-32** 250 PSI (17.2 bar) @ 400°F (204.44°C)

Shipping Weight: Approx. 2 lbs. (0.91 kg)
W Option: 6 lbs.

Dimensions:

Width:	4" (10.16 cm)	W Option	7.5" (19.0 cm)
Height:	4.25" (10.80 cm)		7.5" (19.0 cm)
Depth:	3.5" (8.89 cm)		5.9" (14.9 cm)

Get the Advantage



4700 Harold Abitz Dr
Muskogee, OK 74403
800-743-7431 phone
888-686-6212 fax
www.advantagecontrols.com