

MegaTron
Controller
Supplemental

Modbus / TCP
Communications
Manual

Advantage Controls
P.O. Box 1472
Muskogee, OK 74402
Phone: 800-743-7431
Fax: 888-686-6212
www.advantagecontrols.com
email: support@advantagecontrols.com

10/2009

Modbus / TCP Communications Manual Table of Contents

Contents	Page
I. Modbus/TCP Introduction	3
II. Modbus/TCP Overview	3
III. Modbus/TCP Data Dictionary	4
Data Types	4
Controller Data	4
Configuration Data	4
Alarm Data	5
Sensor Data	12
Relay Data.....	12
mA Output Data.....	12

I. Modbus Introduction

The Advantage Controls MegaTron is capable of supporting TCP/IP communications via Ethernet and Data Modem. This allows for connections to our custom embedded web server via local networks and our browser based WebAdvantage service. Advantage Controls has now implemented Modbus/TCP support which allows interfacing with more customizable PC applications using HMI/SCADA and stand-alone HMI systems.

II. Modbus Overview

Modbus is a messaging protocol developed by Modicon in 1979. It's used to establish a client-server communication between Modbus intelligent enabled devices. Modbus is a de facto standard open and widely used network protocol within industrial manufacturing environments. The protocol is used to transfer analog I/O and register data between Modbus enabled systems.

The Advantage Controls MegaTron utilizes Modbus/TCP protocol via an Ethernet handoff. Modbus is an application layer messaging protocol, located at level 7 of the OSI model providing client-server communications between devices positioned different types of buses or networks.

* For more information about Modbus please visit www.modbus.org.

III. Modbus/TCP Data Dictionary - Rev. JA. 12.1

Data Types

Data Types
Bit - 1-Bit (16 Bits per Register)
Float - 32-Bit Floating Point
Long - 32-Bit Integer
Short - 16-Bit Integer
String - 8-Bits (2 per Register)

Controller Data

Controller Data	Addr.	Reg. Qty.	Size	Type
Name	0001	16	32	String
Serial Number	0017	16	32	String
Firmware Version	0033	16	32	String
Date	0049	4	8	String
Time	0053	4	8	String
Day of Week	0057	1	1	Short

Configuration Data

Configuration Data	Addr.	Reg. Size	Qty.	Total	Type
Conductivity - Set Pt #1 [1-4]	1001	1	4	4	Short
Conductivity - Set Pt #2 [1-4]	1005	1	4	4	Short
Conductivity - High Alarm Set Pt [1-4]	1009	1	4	4	Short
Conductivity - Low Alarm Set Pt [1-4]	1013	1	4	4	Short
Makeup Cond. - Set Pt #1 [1-4]	1017	1	4	4	Short
Makeup Cond. - High Alarm Set Pt [1-4]	1021	1	4	4	Short
Makeup Cond. - Low Alarm Set Pt [1-4]	1025	1	4	4	Short
pH - Set Pt #1 [1-4]	1029	2	4	8	Float
pH - Set Pt #2 [1-4]	1037	2	4	8	Float
pH - High Alarm Set Pt [1-4]	1045	2	4	8	Float
pH - Low Alarm Set Pt [1-4]	1053	2	4	8	Float
ORP - Set Pt #1 [1-4]	1061	2	4	8	Float
ORP - Set Pt #2 [1-4]	1069	2	4	8	Float
ORP - High Alarm Set Pt [1-4]	1077	2	4	8	Float
ORP - Low Alarm Set Pt [1-4]	1085	2	4	8	Float
System Temp. - Set Pt #1 [1-4]	1093	2	4	8	Float
System Temp. - High Alarm Set Pt [1-4]	1101	2	4	8	Float
System Temp. - Low Alarm Set Pt [1-4]	1109	2	4	8	Float
Auxiliary Temp. - Set Pt #1 [1-4]	1117	2	4	8	Float
Auxiliary Temp. - High Alarm Set Pt [1-4]	1125	2	4	8	Float
Auxiliary Temp. - Low Alarm Set Pt [1-4]	1133	2	4	8	Float
Delta Temp. - Set Pt #1 [1-4]	1141	2	4	8	Float
Delta Temp. - High Alarm Set Pt [1-4]	1149	2	4	8	Float
Delta Temp. - Low Alarm Set Pt [1-4]	1157	2	4	8	Float
Flow Switch - Configuration [1-4]	1165	1	4	4	Short
Temperature Scale	1169	1	1	1	Short

Alarm Data

Alarm Data	Address	Bit(s)	Type
SYS1 COND	2001:1	1	Bit
SYS1 pH	2001:2	1	Bit
SYS1 ORP	2001:3	1	Bit
SYS1 TEMP 1	2001:4	1	Bit
SYS1 TEMP 2	2001:5	1	Bit
SYS1 DELTA TEMP	2001:6	1	Bit
SYS1 TIMER1	2001:7	1	Bit
SYS1 TIMER2	2001:8	1	Bit
SYS1 TIMER3	2001:9	1	Bit
SYS1 TIMER4	2001:10	1	Bit
SYS1 TIMER5	2001:11	1	Bit
SYS1 ALL ALARMS	2001:12	1	Bit
SYS1 HI COND	2001:13	1	Bit
SYS1 LO COND	2001:14	1	Bit
SYS1 COND LIMIT	2001:15	1	Bit
SYS1 HI pH	2001:16	1	Bit
SYS1 LO pH	2002:1	1	Bit
SYS1 ph LIMIT	2002:2	1	Bit
SYS1 HI ORP	2002:3	1	Bit
SYS1 LO ORP	2002:4	1	Bit
SYS1 ORP LIMIT	2002:5	1	Bit
SYS1 HI TEMP 1	2002:6	1	Bit
SYS1 LO TEMP 1	2002:7	1	Bit
SYS1 HI TEMP 2	2002:8	1	Bit
SYS1 LO TEMP 2	2002:9	1	Bit
SYS1 HI DELTA TEMP	2002:10	1	Bit
SYS1 LO DELTA TEMP	2002:11	1	Bit
SYS1 NO FLOW	2002:12	1	Bit
SYS1 DIGITAL INPUT 1	2002:13	1	Bit
SYS1 DIGITAL INPUT 2	2002:14	1	Bit
SYS1 DIGITAL INPUT 3	2002:15	1	Bit
SYS1 DIGITAL INPUT 4	2002:16	1	Bit
SYS1 DIGITAL INPUT 5	2003:1	1	Bit
SYS1 MCND	2003:2	1	Bit
SYS1 HI MCND	2003:3	1	Bit
SYS1 LO MCND	2003:4	1	Bit
SYS1 MCND LIMIT	2003:5	1	Bit
SYS1 NOTE 1 HI	2003:6	1	Bit

SYS1 NOTE 2 HI	2003:7	1	Bit
SYS1 NOTE 3 HI	2003:8	1	Bit
SYS1 NOTE 4 HI	2003:9	1	Bit
SYS1 NOTE 5 HI	2003:10	1	Bit
SYS1 NOTE 6 HI	2003:11	1	Bit
SYS1 NOTE 7 HI	2003:12	1	Bit
SYS1 NOTE 8 HI	2003:13	1	Bit
SYS1 NOTE 9 HI	2003:14	1	Bit
SYS1 NOTE 10 HI	2003:15	1	Bit
SYS1 NOTE 1 LO	2003:16	1	Bit
SYS1 NOTE 2 LO	2004:1	1	Bit
SYS1 NOTE 3 LO	2004:2	1	Bit
SYS1 NOTE 4 LO	2004:3	1	Bit
SYS1 NOTE 5 LO	2004:4	1	Bit
SYS1 NOTE 6 LO	2004:5	1	Bit
SYS1 NOTE 7 LO	2004:6	1	Bit
SYS1 NOTE 8 LO	2004:7	1	Bit
SYS1 NOTE 9 LO	2004:8	1	Bit
SYS1 NOTE 10 LO	2004:9	1	Bit
SYS1 NOTE 1 TIME	2004:10	1	Bit
SYS1 NOTE 2 TIME	2004:11	1	Bit
SYS1 NOTE 3 TIME	2004:12	1	Bit
SYS1 NOTE 4 TIME	2004:13	1	Bit
SYS1 NOTE 5 TIME	2004:14	1	Bit
SYS1 NOTE 6 TIME	2004:15	1	Bit
SYS1 NOTE 7 TIME	2004:16	1	Bit
SYS1 NOTE 8 TIME	2005:1	1	Bit
SYS1 NOTE 9 TIME	2005:2	1	Bit
SYS1 NOTE 10 TIME	2005:3	1	Bit
SYS1 pH2	2005:4	1	Bit
SYS2 COND	2008:1	1	Bit
SYS2 pH	2008:2	1	Bit
SYS2 ORP	2008:3	1	Bit
SYS2 TEMP 1	2008:4	1	Bit
SYS2 TEMP 2	2008:5	1	Bit
SYS2 DELTA TEMP	2008:6	1	Bit
SYS2 TIMER1	2008:7	1	Bit
SYS2 TIMER2	2008:8	1	Bit
SYS2 TIMER3	2008:9	1	Bit
SYS2 TIMER4	2008:10	1	Bit
SYS2 TIMER5	2008:11	1	Bit

SYS2 ALL ALARMS	2008:12	1	Bit
SYS2 HI COND	2008:13	1	Bit
SYS2 LO COND	2008:14	1	Bit
SYS2 COND LIMIT	2008:15	1	Bit
SYS2 HI ph	2008:16	1	Bit
SYS2 LO ph	2009:1	1	Bit
SYS2 ph LIMIT	2009:2	1	Bit
SYS2 HI ORP	2009:3	1	Bit
SYS2 LO ORP	2009:4	1	Bit
SYS2 ORP LIMIT	2009:5	1	Bit
SYS2 HI TEMP 1	2009:6	1	Bit
SYS2 LO TEMP 1	2009:7	1	Bit
SYS2 HI TEMP 2	2009:8	1	Bit
SYS2 LO TEMP 2	2009:9	1	Bit
SYS2 HI DELTA TEMP	2009:10	1	Bit
SYS2 LO DELTA TEMP	2009:11	1	Bit
SYS2 NO FLOW	2009:12	1	Bit
SYS2 DIGITAL INPUT 1	2009:13	1	Bit
SYS2 DIGITAL INPUT 2	2009:14	1	Bit
SYS2 DIGITAL INPUT 3	2009:15	1	Bit
SYS2 DIGITAL INPUT 4	2009:16	1	Bit
SYS2 DIGITAL INPUT 5	2010:1	1	Bit
SYS2 MCND	2010:2	1	Bit
SYS2 HI MCND	2010:3	1	Bit
SYS2 LO MCND	2010:4	1	Bit
SYS2 MCND LIMIT	2010:5	1	Bit
SYS2 NOTE 1 HI	2010:6	1	Bit
SYS2 NOTE 2 HI	2010:7	1	Bit
SYS2 NOTE 3 HI	2010:8	1	Bit
SYS2 NOTE 4 HI	2010:9	1	Bit
SYS2 NOTE 5 HI	2010:10	1	Bit
SYS2 NOTE 6 HI	2010:11	1	Bit
SYS2 NOTE 7 HI	2010:12	1	Bit
SYS2 NOTE 8 HI	2010:13	1	Bit
SYS2 NOTE 9 HI	2010:14	1	Bit
SYS2 NOTE 10 HI	2010:15	1	Bit
SYS2 NOTE 1 LO	2010:16	1	Bit
SYS2 NOTE 2 LO	2011:1	1	Bit
SYS2 NOTE 3 LO	2011:2	1	Bit
SYS2 NOTE 4 LO	2011:3	1	Bit
SYS2 NOTE 5 LO	2011:4	1	Bit

SYS2 NOTE 6 LO	2011:5	1	Bit
SYS2 NOTE 7 LO	2011:6	1	Bit
SYS2 NOTE 8 LO	2011:7	1	Bit
SYS2 NOTE 9 LO	2011:8	1	Bit
SYS2 NOTE 10 LO	2011:9	1	Bit
SYS2 NOTE 1 TIME	2011:10	1	Bit
SYS2 NOTE 2 TIME	2011:11	1	Bit
SYS2 NOTE 3 TIME	2011:12	1	Bit
SYS2 NOTE 4 TIME	2011:13	1	Bit
SYS2 NOTE 5 TIME	2011:14	1	Bit
SYS2 NOTE 6 TIME	2011:15	1	Bit
SYS2 NOTE 7 TIME	2011:16	1	Bit
SYS2 NOTE 8 TIME	2012:1	1	Bit
SYS2 NOTE 9 TIME	2012:2	1	Bit
SYS2 NOTE 10 TIME	2012:3	1	Bit
SYS2 pH2	2012:4	1	Bit
SYS3 COND	2015:1	1	Bit
SYS3 pH	2015:2	1	Bit
SYS3 ORP	2015:3	1	Bit
SYS3 TEMP 1	2015:4	1	Bit
SYS3 TEMP 2	2015:5	1	Bit
SYS3 DELTA TEMP	2015:6	1	Bit
SYS3 TIMER1	2015:7	1	Bit
SYS3 TIMER2	2015:8	1	Bit
SYS3 TIMER3	2015:9	1	Bit
SYS3 TIMER4	2015:10	1	Bit
SYS3 TIMER5	2015:11	1	Bit
SYS3 ALL ALARMS	2015:12	1	Bit
SYS3 HI COND	2015:13	1	Bit
SYS3 LO COND	2015:14	1	Bit
SYS3 COND LIMIT	2015:15	1	Bit
SYS3 HI ph	2015:16	1	Bit
SYS3 LO ph	2016:1	1	Bit
SYS3 ph LIMIT	2016:2	1	Bit
SYS3 HI ORP	2016:3	1	Bit
SYS3 LO ORP	2016:4	1	Bit
SYS3 ORP LIMIT	2016:5	1	Bit
SYS3 HI TEMP 1	2016:6	1	Bit
SYS3 LO TEMP 1	2016:7	1	Bit
SYS3 HI TEMP 2	2016:8	1	Bit
SYS3 LO TEMP 2	2016:9	1	Bit

SYS3 HI DELTA TEMP	2016:10	1	Bit
SYS3 LO DELTA TEMP	2016:11	1	Bit
SYS3 NO FLOW	2016:12	1	Bit
SYS3 DIGITAL INPUT 1	2016:13	1	Bit
SYS3 DIGITAL INPUT 2	2016:14	1	Bit
SYS3 DIGITAL INPUT 3	2016:15	1	Bit
SYS3 DIGITAL INPUT 4	2016:16	1	Bit
SYS3 DIGITAL INPUT 5	2017:1	1	Bit
SYS3 MCND	2017:2	1	Bit
SYS3 HI MCND	2017:3	1	Bit
SYS3 LO MCND	2017:4	1	Bit
SYS3 MCND LIMIT	2017:5	1	Bit
SYS3 NOTE 1 HI	2017:6	1	Bit
SYS3 NOTE 2 HI	2017:7	1	Bit
SYS3 NOTE 3 HI	2017:8	1	Bit
SYS3 NOTE 4 HI	2017:9	1	Bit
SYS3 NOTE 5 HI	2017:10	1	Bit
SYS3 NOTE 6 HI	2017:11	1	Bit
SYS3 NOTE 7 HI	2017:12	1	Bit
SYS3 NOTE 8 HI	2017:13	1	Bit
SYS3 NOTE 9 HI	2017:14	1	Bit
SYS3 NOTE 10 HI	2017:15	1	Bit
SYS3 NOTE 1 LO	2017:16	1	Bit
SYS3 NOTE 2 LO	2018:1	1	Bit
SYS3 NOTE 3 LO	2018:2	1	Bit
SYS3 NOTE 4 LO	2018:3	1	Bit
SYS3 NOTE 5 LO	2018:4	1	Bit
SYS3 NOTE 6 LO	2018:5	1	Bit
SYS3 NOTE 7 LO	2018:6	1	Bit
SYS3 NOTE 8 LO	2018:7	1	Bit
SYS3 NOTE 9 LO	2018:8	1	Bit
SYS3 NOTE 10 LO	2018:9	1	Bit
SYS3 NOTE 1 TIME	2018:10	1	Bit
SYS3 NOTE 2 TIME	2018:11	1	Bit
SYS3 NOTE 3 TIME	2018:12	1	Bit
SYS3 NOTE 4 TIME	2018:13	1	Bit
SYS3 NOTE 5 TIME	2018:14	1	Bit
SYS3 NOTE 6 TIME	2018:15	1	Bit
SYS3 NOTE 7 TIME	2018:16	1	Bit
SYS3 NOTE 8 TIME	2019:1	1	Bit
SYS3 NOTE 9 TIME	2019:2	1	Bit

SYS3 NOTE 10 TIME	2019:3	1	Bit
SYS3 pH2	2019:4	1	Bit
SYS4 COND	2022:1	1	Bit
SYS4 pH	2022:2	1	Bit
SYS4 ORP	2022:3	1	Bit
SYS4 TEMP 1	2022:4	1	Bit
SYS4 TEMP 2	2022:5	1	Bit
SYS4 DELTA TEMP	2022:6	1	Bit
SYS4 TIMER1	2022:7	1	Bit
SYS4 TIMER2	2022:8	1	Bit
SYS4 TIMER3	2022:9	1	Bit
SYS4 TIMER4	2022:10	1	Bit
SYS4 TIMER5	2022:11	1	Bit
SYS4 ALL ALARMS	2022:12	1	Bit
SYS4 HI COND	2022:13	1	Bit
SYS4 LO COND	2022:14	1	Bit
SYS4 COND LIMIT	2022:15	1	Bit
SYS4 HI ph	2022:16	1	Bit
SYS4 LO ph	2023:1	1	Bit
SYS4 ph LIMIT	2023:2	1	Bit
SYS4 HI ORP	2023:3	1	Bit
SYS4 LO ORP	2023:4	1	Bit
SYS4 ORP LIMIT	2023:5	1	Bit
SYS4 HI TEMP 1	2023:6	1	Bit
SYS4 LO TEMP 1	2023:7	1	Bit
SYS4 HI TEMP 2	2023:8	1	Bit
SYS4 LO TEMP 2	2023:9	1	Bit
SYS4 HI DELTA TEMP	2023:10	1	Bit
SYS4 LO DELTA TEMP	2023:11	1	Bit
SYS4 NO FLOW	2023:12	1	Bit
SYS4 DIGITAL INPUT 1	2023:13	1	Bit
SYS4 DIGITAL INPUT 2	2023:14	1	Bit
SYS4 DIGITAL INPUT 3	2023:15	1	Bit
SYS4 DIGITAL INPUT 4	2023:16	1	Bit
SYS4 DIGITAL INPUT 5	2024:1	1	Bit
SYS4 MCND	2024:2	1	Bit
SYS4 HI MCND	2024:3	1	Bit
SYS4 LO MCND	2024:4	1	Bit
SYS4 MCND LIMIT	2024:5	1	Bit
SYS4 NOTE 1 HI	2024:6	1	Bit
SYS4 NOTE 2 HI	2024:7	1	Bit

SYS4 NOTE 3 HI	2024:8	1	Bit
SYS4 NOTE 4 HI	2024:9	1	Bit
SYS4 NOTE 5 HI	2024:10	1	Bit
SYS4 NOTE 6 HI	2024:11	1	Bit
SYS4 NOTE 7 HI	2024:12	1	Bit
SYS4 NOTE 8 HI	2024:13	1	Bit
SYS4 NOTE 9 HI	2024:14	1	Bit
SYS4 NOTE 10 HI	2024:15	1	Bit
SYS4 NOTE 1 LO	2024:16	1	Bit
SYS4 NOTE 2 LO	2025:1	1	Bit
SYS4 NOTE 3 LO	2025:2	1	Bit
SYS4 NOTE 4 LO	2025:3	1	Bit
SYS4 NOTE 5 LO	2025:4	1	Bit
SYS4 NOTE 6 LO	2025:5	1	Bit
SYS4 NOTE 7 LO	2025:6	1	Bit
SYS4 NOTE 8 LO	2025:7	1	Bit
SYS4 NOTE 9 LO	2025:8	1	Bit
SYS4 NOTE 10 LO	2025:9	1	Bit
SYS4 NOTE 1 TIME	2025:10	1	Bit
SYS4 NOTE 2 TIME	2025:11	1	Bit
SYS4 NOTE 3 TIME	2025:12	1	Bit
SYS4 NOTE 4 TIME	2025:13	1	Bit
SYS4 NOTE 5 TIME	2025:14	1	Bit
SYS4 NOTE 6 TIME	2025:15	1	Bit
SYS4 NOTE 7 TIME	2025:16	1	Bit
SYS4 NOTE 8 TIME	2026:1	1	Bit
SYS4 NOTE 9 TIME	2026:2	1	Bit
SYS4 NOTE 10 TIME	2026:3	1	Bit
SYS4 pH2	2026:4	1	Bit
MA IN1	2029:1	1	Bit
MA IN1 HIGH	2029:2	1	Bit
MA IN1 LOW	2029:3	1	Bit
MA IN2	2029:4	1	Bit
MA IN2 HIGH	2029:5	1	Bit
MA IN2 LOW	2029:6	1	Bit
MA IN3	2029:7	1	Bit
MA IN3 HIGH	2029:8	1	Bit
MA IN3 LOW	2029:9	1	Bit
MA IN4	2029:10	1	Bit
MA IN4 HIGH	2029:11	1	Bit
MA IN4 LOW	2029:12	1	Bit

MA IN5	2029:13	1	Bit
MA IN5 HIGH	2029:14	1	Bit
MA IN5 LOW	2029:15	1	Bit
MA IN6	2029:16	1	Bit
MA IN6 HIGH	2030:1	1	Bit
MA IN6 LOW	2030:2	1	Bit
MA IN7	2030:3	1	Bit
MA IN7 HIGH	2030:4	1	Bit
MA IN7 LOW	2030:5	1	Bit
MA IN8	2030:6	1	Bit
MA IN8 HIGH	2030:7	1	Bit
MA IN8 LOW	2030:8	1	Bit

Sensor Data

Sensor Data	Addr.	Reg. Size	Qty.	Total	Type
Conductivity [1-4]	3001	1	4	4	Short
Makeup Cond. [1-4]	3005	1	4	4	Short
pH [1-4]	3009	2	4	8	Float
ORP [1-4]	3017	2	4	8	Float
System Temp. [1-4]	3025	2	4	8	Float
Auxiliary Temp. [1-4]	3033	2	4	8	Float
Flow [1-4]	3041	1	4	4	Short
Water Meter #1 - Contact Value [1-4]	3045	2	4	8	Long
Water Meter #2 - Contact Value [1-4]	3053	2	4	8	Long
Makeup Cycles [1-4]	3061	2	4	8	Float

Relay Data

Relay Data	Addr.	Reg. Size	Qty.	Total	Type
Relay [1-20] (See Note #1)	4001	1	20	20	Short

Note #1 0=H-OFF 1=H-ON 2=OFF 3=ON

mA Output Data

mA Output Data	Addr.	Reg. Size	Qty.	Total	Type
Value [1-6]	4201	2	6	12	Float

Get the Advantage in Water Treatment Equipment

Advantage Controls can give you the *Advantage* in products, knowledge and support on all of your water treatment equipment needs.

- Cooling Tower Controllers
- Boiler Blow Down Controllers
- Blow Down Valve Packages
- Solenoid Valves
- Water Meters
- Chemical Metering Pumps
- Corrosion Coupon Racks
- Chemical Solution Tanks
- Solid Feed Systems
- Feed Timers
- Filter Equipment
- Glycol Feed Systems
- Pre Fabricated Systems

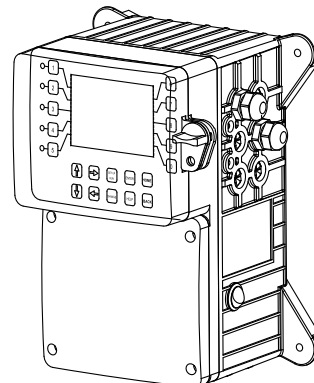
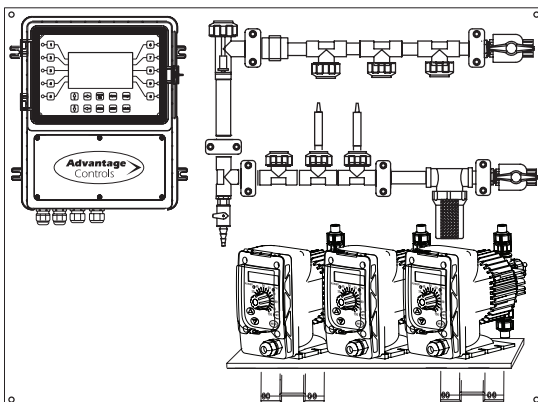
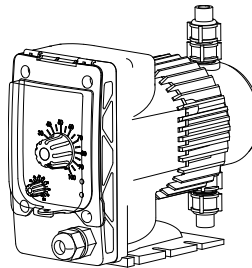
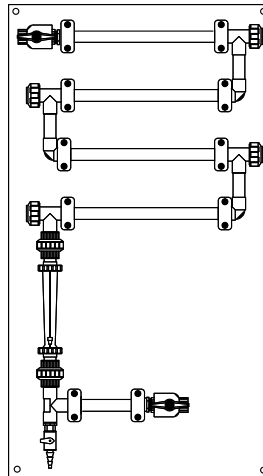
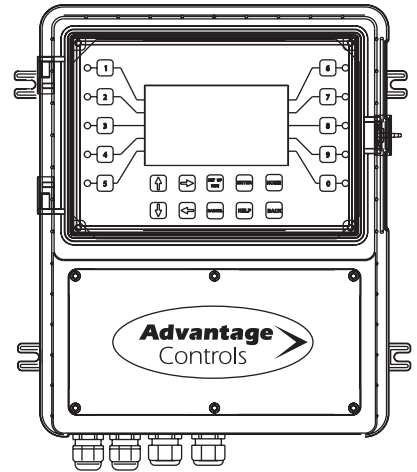
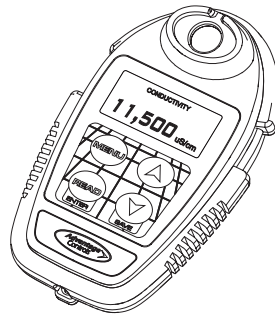

Get the Advantage

