

# Economy Glycol Feeder

*For Closed  
Loop Systems*



## Key Features

- Compact design
- Wall mountable
- Push to test pump
- 5 or 10 gallon options
- Low level shut-off
- ETL approved
- Adjustable pressure
- Economical

## Application

Advantage Controls EGF glycol feeders provide a compact wall mountable system for feeding and pressurizing small closed loops for snow and ice melt circuits, small boilers chillers, solar and other heating/cooling coils.

The unique tank design and SS mounting bracket hold the brass plumbing assembly that includes a 6-30 PSI adjustable pressure, gauge, shut-off valve, 30 gpd at 100 PSI feed pump and low level shut-off switch in one economical package.

## Build a Model

EGF - \_ - \_

### TANK SELECTION

- 05 = 5 gal tank with 30 gpd @ 100 PSI pump  
10 = 10 gal tank with 30 gpd @ 100 PSI pump

### OPTIONS

- A2 = 240 volt, no plug  
B = 15 gpd @ 150 PSI pump  
C = Red pumping housing (instead of green)  
C1 = Blue pump housing (instead of green)  
P = High pressure switch 20-120 PSI

## Specifications

**Electrical Input** 120 VAC, 60 Hz

**Plumbing** Brass

**Pressure Gauge** 0-100 PSI (0-6.9 bar)

### Dimensions

#### 5 gal:

W 11.75" (29.8 cm)

H 16.15" (41.1 cm)

D 11.81" (30 cm)

#### 10 gal:

W 13" (33 cm)

H 23.117" (58.72 cm)

D 15" (38 cm)

### Shipping Weight

#### 5 gal:

16 lbs (7.26 kg) approx.

#### 10 gal:

17 lbs (7.71 kg) approx.

5 gal. Model

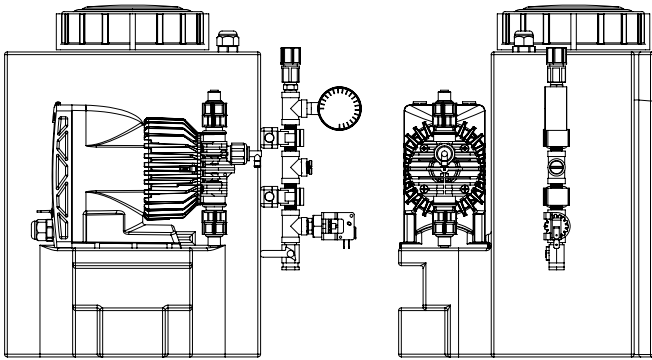

10 gal. Model

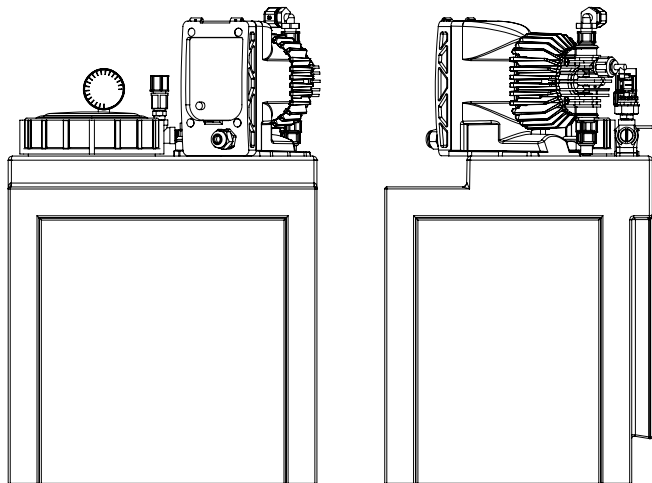

Advantage Controls offers a full line of water treatment equipment including web based monitors, metering pumps, and large glycol feed systems.

**Get the Advantage**



4700 Harold Abitz Dr  
Muskogee, OK 74403  
918-686-6211 phone  
888-686-6212 fax  
[www.advantagecontrols.com](http://www.advantagecontrols.com)